

UPC-101 Slotted Outlet Plenum Kit

Application

The *Unico System* UPC-101 slotted takeoffs are specially designed to deliver air directly from the main plenum into a room. It is very useful if there is no space to run supply tubing and the plenum is covered by a soffit, or when exposed ductwork is utilized. It comes standard with a white rectangular plastic trim plate with a slotted opening for the nozzle portion of the outlet. The trim plate is the only part that is seen in the occupied space, and can be painted to match any decor.

General

The *Unico System* slotted takeoff is made of galvanized sheet metal and is designed to fit the trim plate. The takeoff is designed for either a round or square 1-inch (25-mm) fiberglass main plenum, or metal ductwork.

Design

Unlike the standard Unico outlets, the plenum slotted outlet does not use any 2-inch (50 mm) ducting which means the plenum slotted outlet does not offer any sound attenuation. Also, the pressure drop through the opening is considerably less than a typical branch duct.

To compensate for the lack of a sound attenuator, the main plenum must have an acoustical lining. We recommend at least 1 inch (25 mm) of fiberglass duct

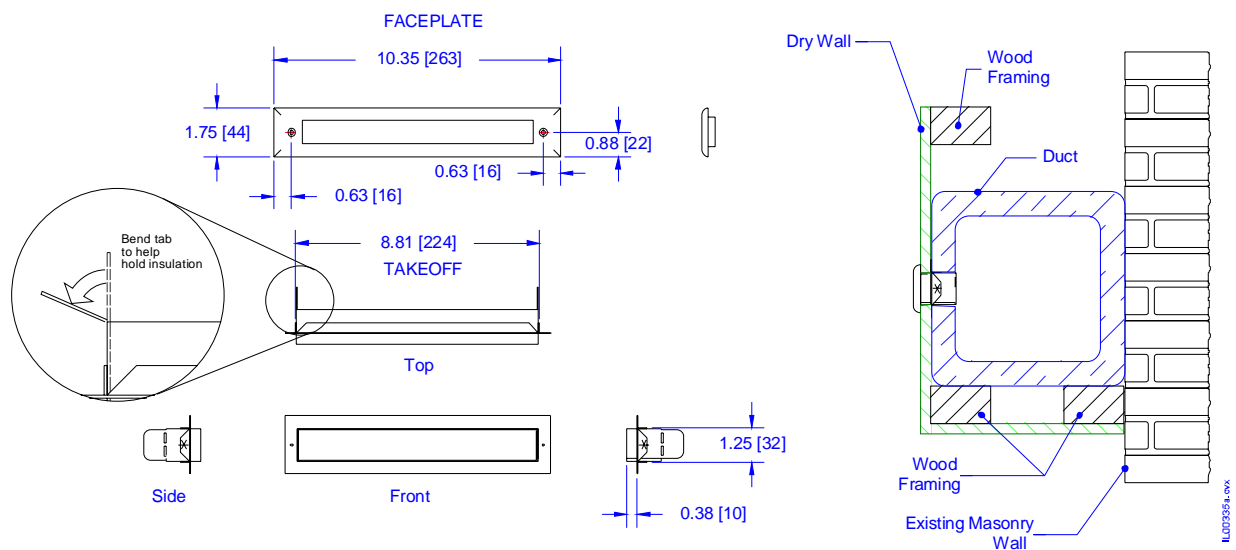
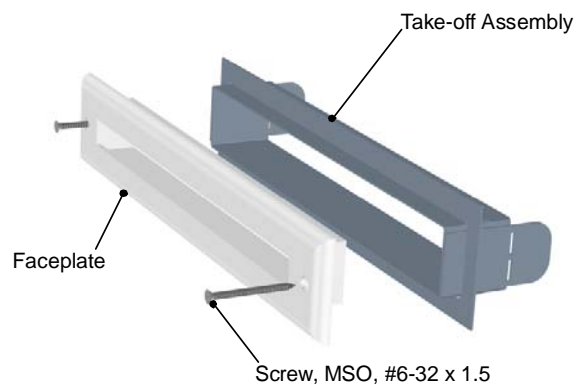

Figure 1. Slotted Outlet and Trim Plate Dimensions and Cross-Section (with Wall shown)

lining. If fiberglass is not allowed, use acoustical foam board.

Sound is also dependant on velocity so we recommend at least 7 outlets per ton. Using more will further reduce the sound.

For wall installations the UPC-101 should be located high on the wall and a minimum of 5-inch (13-cm) below the ceiling. For ceiling installations locate it a minimum of 4-inches (10-cm) away from the adjacent wall.

Installation

Cut a rectangular 9.0 x 1.38 inch (228 x 35 mm) hole in the duct to fit metal bracket. For 1-inch (25 mm) fiberglass duct, bend tabs out to secure bracket. For metal duct, remove tabs then secure bracket with double-sided tape or caulk.

Verification

As mentioned above, the plenum slotted outlet is designed for 20 to 35 CFM. Unlike our 90° or straight slotted outlet (UPC-66/67/68), the air flow does not come out of the opening in a predictably flow pattern (see Figure 2) so the turbometer cannot be used directly to measure airflow. To verify the airflow you must use a straight slotted outlet (UPC-68) to capture the airflow first. Then use the turbometer to measure the airflow as shown in Figure 3.

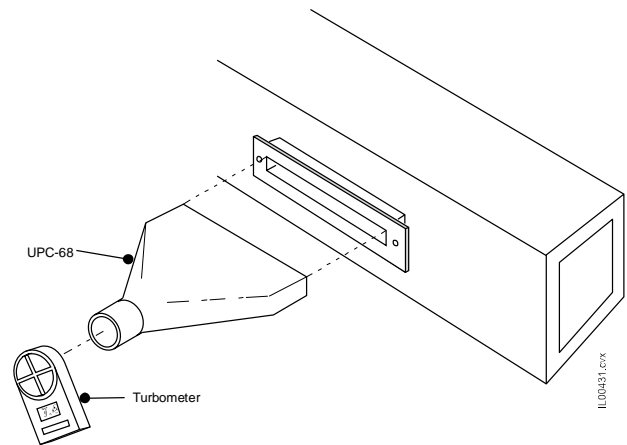

Figure 3. Measuring airflow.

After measuring the airflow with turbometer, multiply the “knots” reading by 3.75 to determine the CFM (multiply the “knots” by 1.77 to get L/s).

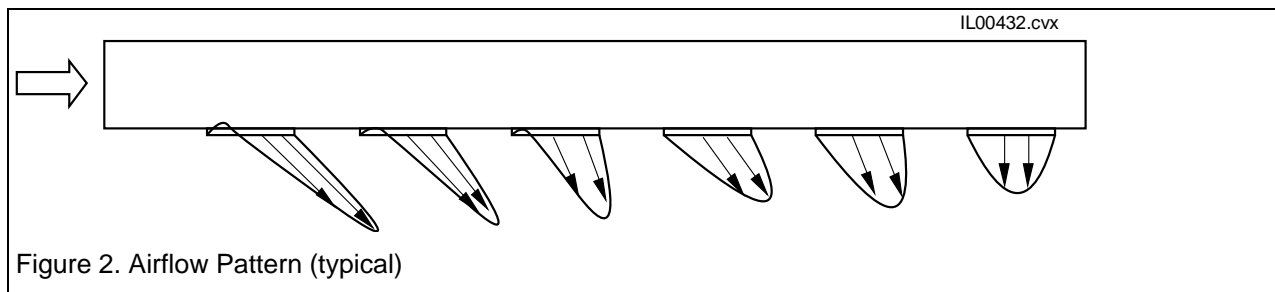

Figure 2. Airflow Pattern (typical)