

# VERTICAL AHU ENGINEERING SPECIFICATIONS

BULLETIN 20-019

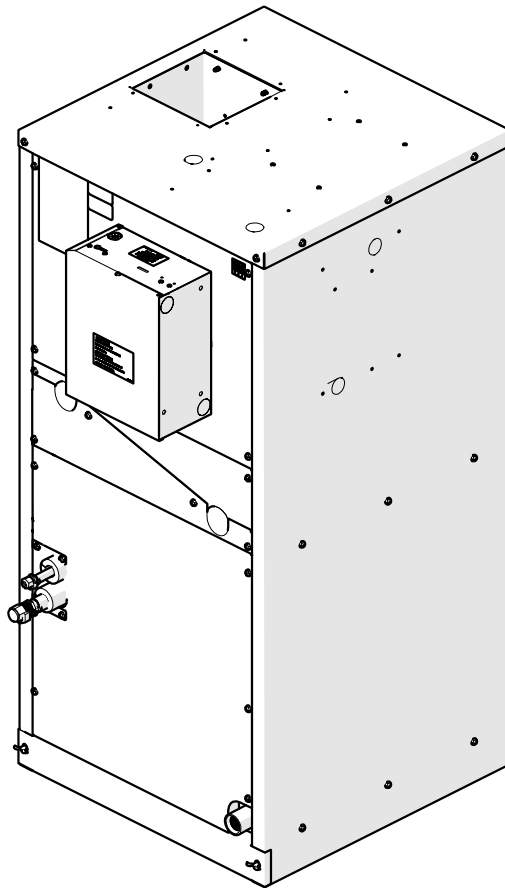

# TABLE OF CONTENTS

<b>DESIGN &amp; SPECIFICATIONS.....</b>	<b>3</b>
APPLICATIONS.....	3
CABINET CONSTRUCTION.....	3
FEATURES AND CONTROLS.....	3
DIMENSIONAL DATA.....	5
SPECIFICATIONS.....	6
HOT WATER COIL PERFORMANCE.....	8
CHILLED WATER COIL PERFORMANCE (COOLING MODE).....	10
CHILLED WATER COIL PERFORMANCE (HEATING MODE).....	11
BLOWER PERFORMANCE.....	14
ACOUSTICAL DATA.....	17

Certified to UL Standard 1995  
Conforms to CAN/CSA Standard C22.2 NO. 236



Unico products comply with the European regulations that guarantee product safety.

# DESIGN & SPECIFICATIONS

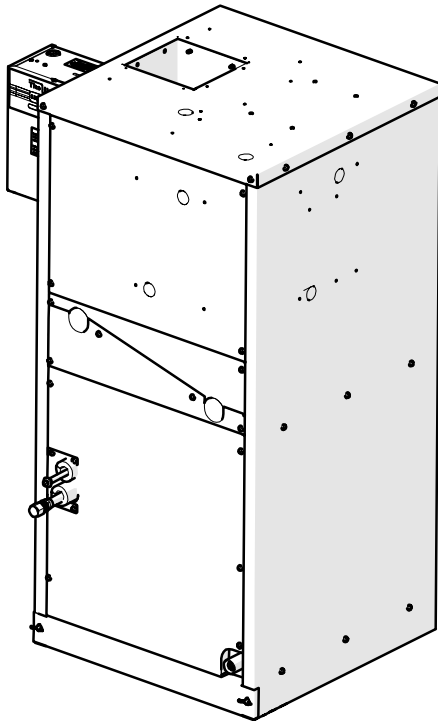

## Model Number Key

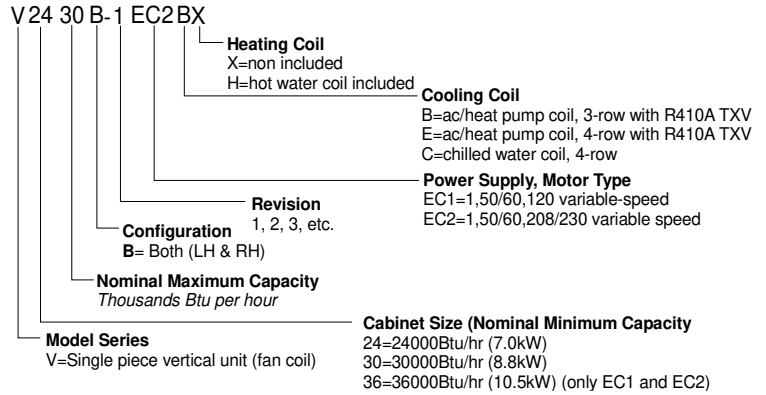

## APPLICATIONS

The Unico System is a complete indoor comfort system that includes an indoor fan coil unit and small duct system. The fan coil unit and duct system were designed to operate together to provide the proper airflow in every installation. The conditioned air is supplied through a series of two-inch diameter ducts as a stream of air that entrains and mixes with the room air. This process of aspiration produces a more even temperature distribution in the room than a conventional system.

The Unico vertical air handler Unit is a single packaged unit in a vertical up-flow configuration.

For cooling, the unit is designed for R-410A refrigerant (both A/C and Heat Pump) or a chilled water coil. For heating, the unit offers an optional hot water coil or you may use an electric heater (Refer to Bulletin 30-34 for proper heater).

## CABINET CONSTRUCTION

The cabinet is fully insulated with 1" closed cell rubber insulation. The cabinet is constructed of 22 gauge (0.7-mm) galvanized steel with removable access panels on the front for ease of service. See dimensional drawing.

## FEATURES AND CONTROLS

The following table shows a comparison of the various features.

Table 1. Feature Summary and Comparison

Control Box Configuration	EC
Balanced wheels	✓
Direct drive motor	✓
Shaft key connection	✓
Control voltage transformer	✓
Screw terminal connections	✓
Heat pump AFS bypass	✓
Adjustable low airflow mode	✓
Number of modes of operation	6
Requires restrictor plate to adjust air flow	NO
Programmed constant air flow	✓
Heating (boiler) relay	✓
Cooling (chiller) relay	✓
Chilled water relay	✓
Efficient ventilation mode	✓
ASHRAE 62.2 compliance mode	✓
Point-to-point wiring	✓
Electric heater fan interlock	✓
Electric heater stage 3 lockout protection	✓
EAC, HRV, or ERV relay	✓
Potable water circulation	✓
Humidifier compatibility	✓
Soft-start and soft-stop	✓
Low airflow indicator	✓
Preset customizable airflow settings	✓
Built-in airflow diagnostics	✓
Optimized for zone damper systems	✓

*Balanced wheels* – All blower wheels are individually balanced.

*Direct drive motor* – The wheel is mounted directly to the motor shaft to improve drive efficiency and lower costs.

*Shaft key* – The wheel is attached to the motor shaft using a square keyway which is more secure than a simple set screws.

*Control voltage transformer* – a 50VA 24-volt transformer which provides control voltage power to the thermostat, electric heaters, and other optional equipment.

*Screw terminal connections* – terminal blocks with large screws and wire washers to securely connect the control wires.

*Heat pump AFS bypass* – removes the anti-frost switch (AFS) from the circuit during heat pump heating mode which eliminates nuisance shutdowns during defrost mode.

*Boiler relay* – The SCB includes a separate dry-contact relay that can be used to turn on the boiler, boiler pump, or hot water coil valve.

*Modes of operation* –The EC control board has 6 modes (Fan-Only, Low-Cool, High-Cool, Low-Heat, High-Heat, and Emergency-Heat).

*Adjustable low airflow mode*–The EC board allows the user to program the airflow for each mode.

*Point-to-point wiring* – The control boards have separate terminals for the thermostat, electric heater, outdoor condenser, and other options for easy wiring and troubleshooting.

*Electric heater fan interlock* – This is a safety feature that prevents the heater from energizing when there is low or no airflow. This prevents the heating elements from overheating, which can severely reduce their useful life.

*Electric heater stage 3 lockout* – The control board includes a lockout feature to prevent the third stage of the electric heater from turning on if the heat pump is also on. This prevents nuisance shutdowns from overheating the electric heater.

*Chilled water relay* – The control box includes a separate dry-contact relay (ColdW) to turn on a chiller or zone pump.

*Fan cycling* – The control board includes a separate switch to provide periodic cycling of the fan to reduce the chance for water to collect in the ducts if located in a cold space and not used, or to provide periodic fresh air if connected to a fresh air source.

*ASHRAE 62.2 Compliant* – The ECMconfig software allows the user to specify the required fresh air and percentage being brought in. The control board will monitor and maintain the proper fresh air inventory in compliance with ASHRAE 62.2.

*EAC, ERV, or HRV relay* – For optimum indoor air quality, the control board includes a dry-contact relay to turn on an electronic air cleaner, energy recovery ventilator, or heat recovery ventilator any time the fan is on.

*Potable water circulation* – For improved health safety, the control board provides a switch-selectable feature to turn on the boiler pump periodically (if installed as part of a domestic water system) to prevent the formation of stagnant water.

*Humidifier compatibility* – The control board includes the ability to connect a humidistat and a humidifier so that the humidistat turns on the humidifier when needed. The user may choose whether the fan with humidifier operates at high or low HEAT airflow setting.

*Soft-start and soft-stop* – For quieter operation, the unit will slowly ramp the motor from stop to full speed, and vice versa.

*Constant airflow* – The EC control will deliver the airflow requested without any user adjustments to the duct system, or requiring the user to measure the amperage.

*Low airflow indicator* – The S.M.A.R.T. control board (SCB) includes an indicator light that signals the user if the desired airflow is not being met. This is usually caused by a restrictive duct system or too few outlets.

*Pre-set air flow rate* – The SCB is pre-programmed for two different air flow rates for HIGH-COOL that can be selected with a board mounted switch. Each of the six different modes are a fixed percentage of this airflow.

*Laptop adjustable* – The airflow for each mode of operation is adjustable to any value between the blower minimum and maximum using the ECMconfig software (available for download at [www.unicosystem.com](http://www.unicosystem.com)) and an ordinary USB cable.

*Laptop troubleshooting* – The ECMconfig software will also provide the user with feedback indicating the actual airflow, motor speed, communications between the boards and the motor, and the state of various inputs and outputs.

*Optimized for zoning with hydronic systems* – The ECMconfig software provides an additional feature that allows the user to specify the maximum motor speed so that the motor does not over speed when zone dampers are closed. This prevents the need for bypass loops and pressure switch controls and reduces noise at the outlets caused by the blower trying to maintain a constant airflow with fewer outlets. Setting a maximum airflow to approximate constant static pressure should not be used with a single speed condensing unit. Refer to the Unico Tech Bulletin on zoning for more information.

*Optimized for efficiency and sound* – The EC control will use the lowest motor speed to achieve the required airflow, which minimizes sound and maximizes electrical efficiency.

**DIMENSIONAL DATA**

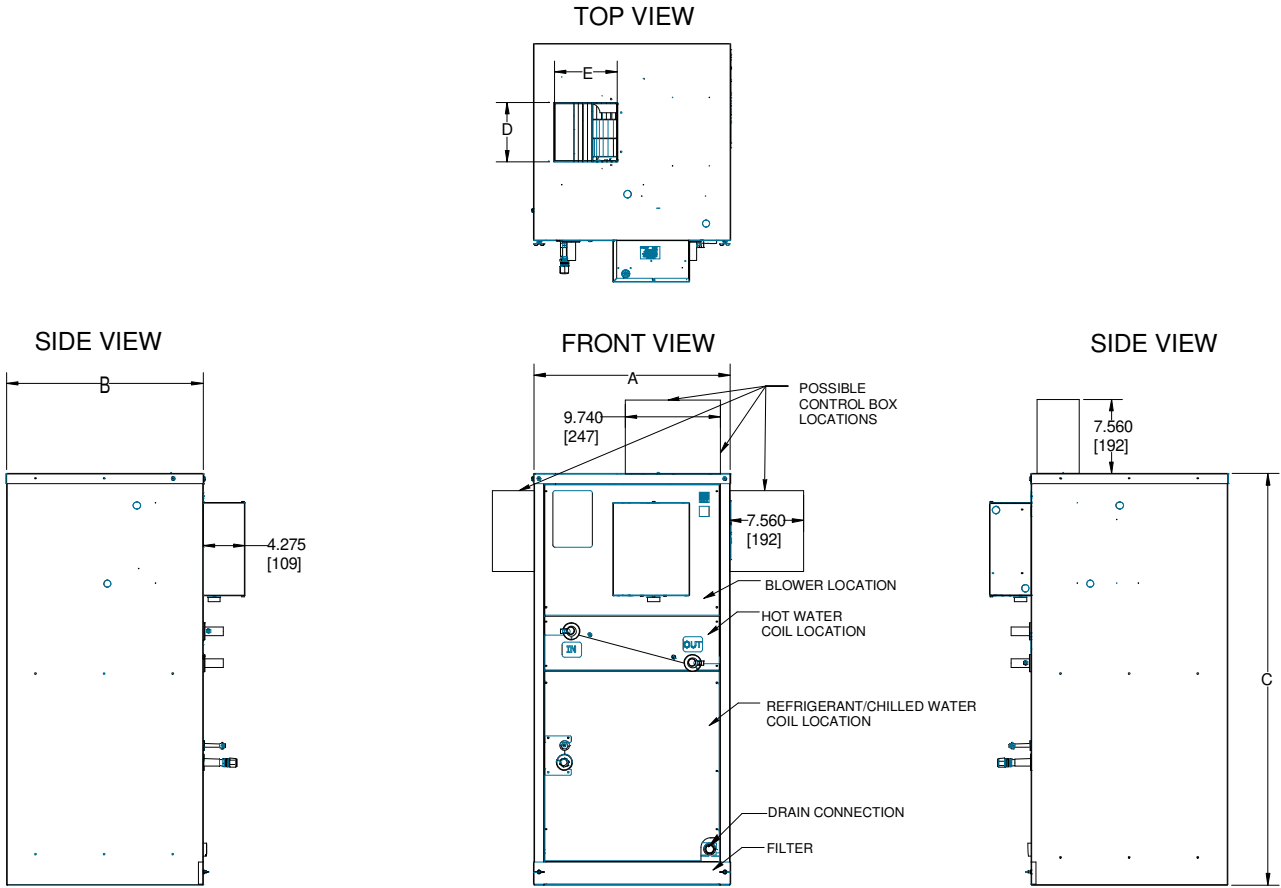

All dimensions in inches [mm]

Note: The control box, expansion valve and U-trap ships inside the spare parts box.

Model	A	B	C	D	E
V2430	20.0 [508]	20.0 [508]	42.0 [1067]	6.0 [152]	6.4 [162]
V3036	20.0 [508]	24.0 [610]	42.0 [1067]	7.1 [179]	6.3 [160]
V3642	23.75 [603]	25.0 [635]	44.0 [1118]	7.16 [182]	6.4 [162]

**Weights**

Model No.	V2430B-1EC1BX		V2430B-1EC1EX		V3036B-1EC1BX		V3036B-1EC1EX		V3642B-1EC1BX		V3642B-1EC1EX	
	V2430B-1EC2BX		V2430B-1EC2EX		V3036B-1EC2BX		V3036B-1EC2EX		V3642B-1EC2BX		V3642B-1EC2EX	
Weight., lbs. [kg]	Net	117 [53]	109 [50]	138 [63]	129 [59]	151 [68]	163 [74]					
	Ship	177 [80]	169 [77]	200 [91]	191 [87]	215 [98]	227 [103]					
Shipping Dimensions Inch [mm]	W	27.2 [692]	27.2 [692]	27.2 [692]	27.2 [692]	31.2 [793]	31.2 [793]					
	D	21.6 [549]	21.6 [549]	24.6 [625]	24.6 [625]	25.6 [651]	25.6 [651]					
	H	44.3 [1125]	44.3 [1125]	44.3 [1125]	44.3 [1125]	46.3 [1176]	46.3 [1176]					

## SPECIFICATIONS

### Blower and Motor Specifications

Model No.	V2430B-1EC1	V3036B-1EC1	V3642B-1EC1	V2430B-1EC2	V3036B-1EC2	V3642B-1EC2
Electrical Power Phase, Hz, Volts	1, 50/60, 120			1, 50/60, 208-230		
Nominal Motor Size hp (kW)	1/2 (0.37)	1 (0.75)		1/2 (0.37)	1 (0.75)	
Motor Type	EC (variable speed)					
Minimum Circuit Ampacity amps	7.0	12.8		4.0	7.7	
Max. Over Current Protection amps	15	20		15	15	
Motor Full Load Current amps	5.6	10.5		3.2	6.1	
Motor Speed RPM	400 – 1800					
Blower Wheel Nom. Diameter in., (mm)	9.5 (241)					
Blower Wheel Width in., (mm)	3.75 (95)	5.0 (127)	5.0 (127)	3.75 (95)	5.0 (127)	5.0 (127)
Nominal Air Flow Rate+ CFM, (L/s)	600 (283)	750 (354)	900 (425)	600 (283)	750 (354)	900 (425)

Plenum Static Pressure+ in. w.c., (kPa)	1.5 (0.373)	1.5(0.373)	1.5 (0.373)	1.5 (0.373)	1.5(0.373)	1.5 (0.373)
Minimum Plenum Size, ID in., (mm)	7 (178)	9 (229)	9 (229)	7 (178)	9 (229)	9 (229)
Sound Pressure Level*	dB(A)	53	53	57	53	53
	NC	48	48	52	48	48

+ Based on full open restrictor and minimum plenum size at 230V.

\* Sound Pressure Level measured for V2430, V3036, and V3642 at 740 CFM, 900 CFM, and 1200 CFM respectively.

### Refrigerant Coil Specifications

System Type*	AC and Heat Pump			AC and Heat Pump		
Model No.	V2430B-1EC1B	V3036B-1EC1B	V3642B-1EC1B	V2430B-1EC1E	V3036B-1EC1E	V3642B-1EC1E
	V2430B-1EC2B	V3036B-1EC2B	V3642B-1EC2B	V2430B-1EC2E	V3036B-1EC2E	V3642B-1EC2E
Coil Part No.	A01948-G01	A01951-G01	A01958-G01	A10914-G01	A01950-G01	A01957-G01
Compatible Condenser Size, ton (kW)	2.0-2.5 (7.0-8.8)	2.5-3.0 (8.8-10.5)	3.0-3.5 (10.5-12.3)	2.0-2.5 (7.0-8.8)	2.5-3.0 (8.8-10.5)	3.0-3.5 (10.5-12.3)
Net Face Area, ft <sup>2</sup> (m <sup>2</sup> )	2.72 (0.25)	3.55 (0.33)	4.75 (0.44)	3.11 (0.29)	4.00 (0.37)	4.75 (0.44)
Tube diameter, in. (mm)	3/8 (9.52)	3/8 (9.52)	3/8 (9.52)	3/8 (9.52)	3/8 (9.52)	3/8 (9.52)
Fin Density, fins/in. (fins/m)	15 (590)	15 (590)	15 (590)	14 (551)	14 (551)	14 (551)
Number of rows	3	3	3	4	4	4
Number of circuits	4	6	6	6	6	8
Design Pressure, psig (MPa)	500 (3.5)	500 (3.5)	500 (3.5)	500 (3.5)	500 (3.5)	500 (3.5)
Refrigerant Type**	R-22, R-407C, R-410A					
Expansion Device	TXV with internal Check Valve (shipped loose)					
TX Valve Part No.	R-22/ R-407C	A00808-002	A00808-004	A00808-004	A00808-002	A00808-004
	R-410A	A00808-013	A00808-014	A00808-014	A00808-013	A00808-014
Suction line	O.D., inch (mm)	5/8 (15.88)	3/4 (19.05)	3/4 (19.05)	5/8 (15.88)	3/4 (19.05)
	Connection, in.	1/2 Male Flare	5/8 Male Flare	3/4 Male Flare	1/2 Male Flare	5/8 Male Flare
Liquid Line	Part No.	A01910-001	A01952-001	A01959-001	A01910-001	A01952-001
	O.D. inch (mm)	3/8 (9.52)	3/8 (9.52)	3/8 (9.52)	3/8 (9.52)	3/8 (9.52)
	Connection, in.	1/4 Male Flare	3/8 Male Flare	3/8 Male Flare	1/4 Male Flare	3/8 Male Flare
Condensate	Connection, in.	3/4 FPT	3/4 FPT	3/4 FPT	3/4 FPT	3/4 FPT

\* Heat pump coil selection depends on outdoor unit model. Refer to AHRI directory for proper match.

\*\* Unit ships with R410-A expansion valve. For R-22 and R-407C, order valve separately.

### Chilled Water Coil Specifications

<b>Model No.</b>		V2430	V3036	V3642
CWC model		A02389-G1	A02395-G01	A02396-G01
No. Rows		4		
Tube diameter	inch [mm]	3/8 [9.5]		
Tube material		Cu		
Fin density	inch <sup>-1</sup> [mm <sup>-1</sup> ]	14 [356]		
Fin material		Al		
Design Pressure	Psig, (kPa)	320 [2206]	320 [2206]	320 [2206]
Net Face Area, ft <sup>2</sup> (m <sup>2</sup> )		3.11 (0.29)	4.00 (0.37)	4.75 (0.44)
No. Circuits		3		
Water Connection Size, ODF Sweat	inch [mm]	7/8 [22.2]	7/8 [22.2]	7/8 [22.2]

### Hot Water Coil Specifications

<b>Model No.</b>		V2430	V3036	V3642	
HWC model		HW-V2430	HW-V3036	HW-V3642	
No. Rows		4			
Tube diameter	inch [mm]	1/2 [12.7]			
Tube material		Cu			
Fin density	inch <sup>-1</sup> [mm <sup>-1</sup> ]	10 [0.40]			
Fin material		Al			
Face Area	inch <sup>2</sup> [m <sup>2</sup> ]	199 [0.128]	259 [0.167]	342 [0.221]	
No. Circuits		3			
Connections, ODF	inch [mm]	7/8 [22.2]			
Weight	Net	Lbs. [kg]	8 [3.6]	11 [5.0]	16 [7.3]
	Ship	Lbs. [kg]	12 [5.4]	15 [6.8]	24 [10.9]
Coil Dimensions	W	inch [mm]	17.38 [442]	21.38 [543]	22.38 [569]
	D	inch [mm]	4.50 [114]	4.50 [114]	4.50 [114]
	H	inch [mm]	15.86 [403]	15.86 [403]	19.61 [498]

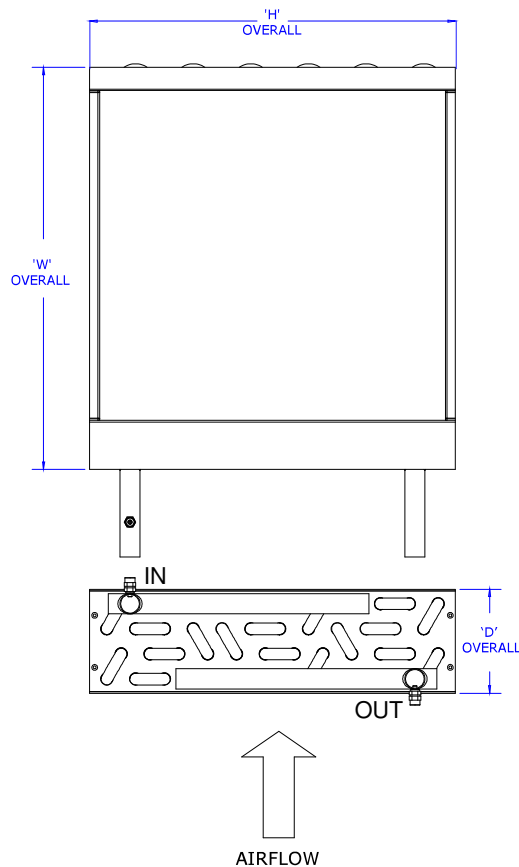

**HOT WATER COIL PERFORMANCE**

<b>V2430</b>			<b>Airflow, SCFM (m³/h)</b>						<b>Water Pressure Drop</b>	
<b>Entering Water Temp</b>	<b>Water Flow Rate</b>		400 (680)		500 (850)		600 (1020)			
			<b>Total Capacity</b>						ft. w.c.	(kPa)
°F (°C)	GPM (L/s)	MBH (kW)	MBH (kW)	MBH (kW)	MBH (kW)	MBH (kW)	MBH (kW)			
100 (38)	2 (0.13)	8.50 (2.48)	9.70 (2.84)	10.7 (3.13)	0.47 (1.40)					
	4 (0.25)	9.40 (2.74)	10.9 (3.21)	12.4 (3.62)	1.60 (4.78)					
	6 (0.38)	9.70 (2.83)	11.4 (3.34)	13.0 (3.81)	3.29 (9.83)					
120 (49)	2 (0.13)	14.3 (4.18)	16.3 (4.78)	18.0 (5.28)	0.47 (1.40)					
	4 (0.25)	15.7 (4.59)	18.4 (5.38)	20.7 (6.08)	1.60 (4.78)					
	6 (0.38)	16.2 (4.74)	19.1 (5.60)	21.8 (6.38)	3.29 (9.83)					
140 (60)	2 (0.13)	20.1 (5.89)	23.0 (6.74)	25.4 (7.46)	0.47 (1.40)					
	4 (0.25)	22.0 (6.46)	25.8 (7.57)	29.2 (8.56)	1.60 (4.78)					
	6 (0.38)	22.7 (6.65)	26.9 (7.87)	30.6 (8.97)	3.29 (9.83)					
160 (71)	2 (0.13)	26.0 (7.62)	29.8 (8.73)	33.0 (9.66)	0.47 (1.40)					
	4 (0.25)	28.4 (8.33)	33.4 (9.78)	37.8 (11.1)	1.60 (4.78)					
	6 (0.38)	29.3 (8.58)	34.7 (10.2)	39.5 (11.6)	3.29 (9.83)					
	4 (0.25)	34.9 (10.2)	40.9 (12.0)	46.3 (13.6)	1.60 (4.78)					
	6 (0.38)	35.9 (10.5)	42.5 (12.4)	48.5 (14.2)	3.29 (9.83)					
Recommended No. of Outlets			12		15		18			

<b>V3036</b>			<b>Airflow, SCFM (m³/h)</b>						<b>Water Pressure Drop</b>	
<b>Entering Water Temp</b>	<b>Water Flow Rate</b>		450 (760)		625 (1060)		750 (1270)			
			<b>Total Capacity</b>						ft. w.c.	(kPa)
°F (°C)	GPM (L/s)	MBH (kW)	MBH (kW)	MBH (kW)	MBH (kW)	MBH (kW)	MBH (kW)			
100 (38)	2 (0.13)	9.80 (2.86)	11.8 (3.46)	12.9 (3.77)	13.9 (3.79)	0.56 (1.7)				
	4 (0.25)	10.8 (4.07)	13.6 (3.16)	15.3 (3.98)	16.8 (4.45)	1.90 (5.7)				
	6 (0.38)	11.1 (4.48)	14.3 (4.92)	16.2 (3.26)	17.9 (4.18)	3.89 (11.6)				
	8 (0.50)	11.3 (4.70)	14.6 (4.75)	16.7 (5.26)	18.6 (3.32)	6.48 (19.4)				
120 (49)	2 (0.13)	16.4 (4.80)	19.9 (5.82)	21.8 (6.35)	23.4 (6.39)	0.56 (1.7)				
	4 (0.25)	18.1 (6.86)	22.8 (5.29)	25.7 (6.68)	28.2 (7.46)	1.90 (5.7)				
	6 (0.38)	18.6 (7.52)	23.9 (8.27)	27.1 (5.46)	30.1 (6.99)	3.89 (11.6)				
	8 (0.50)	18.9 (7.88)	24.4 (7.95)	27.9 (8.82)	31.1 (5.54)	6.48 (19.4)				
140 (60)	2 (0.13)	23.1 (6.76)	28.0 (8.21)	30.8 (8.98)	33.1 (9.02)	0.56 (1.7)				
	4 (0.25)	25.4 (9.69)	32.1 (7.43)	36.2 (9.40)	39.8 (10.5)	1.90 (5.7)				
	6 (0.38)	26.1 (10.6)	33.5 (11.6)	38.2 (7.66)	42.3 (9.83)	3.89 (11.6)				
	8 (0.50)	26.5 (11.1)	34.3 (11.2)	39.2 (12.4)	43.7 (7.77)	6.48 (19.4)				
160 (71)	2 (0.13)	29.8 (8.74)	36.3 (10.6)	39.8 (11.6)	42.8 (11.7)	0.56 (1.7)				
	4 (0.25)	32.7 (12.6)	41.4 (9.59)	46.7 (12.1)	51.4 (13.6)	1.90 (5.7)				
	6 (0.38)	33.7 (13.7)	43.3 (15.1)	49.2 (9.87)	54.6 (12.7)	3.89 (11.6)				
	8 (0.50)	34.2 (14.3)	44.2 (14.4)	50.5 (16.0)	56.3 (10.0)	6.48 (19.4)				
	4 (0.25)	40.1 (11.8)	50.8 (14.9)	57.3 (16.8)	63.1 (18.5)	1.90 (5.7)				
	6 (0.38)	41.3 (12.1)	53.0 (15.5)	60.4 (17.7)	67.0 (19.6)	3.89 (11.6)				
	8 (0.50)	41.8 (12.3)	54.1 (15.9)	61.9 (18.1)	69.1 (20.2)	6.48 (19.4)				
	Recommended No. of Outlets			14		19		23		27

**WARNING!**  
 To prevent injury or damage from high temperatures, do not install floor outlets when operating with discharge temperature above 160°F (71°C).

**Caution**  
 To prevent damage to the EC motor from overheating, do not operate in the shaded region where discharge temperature is more 150 °F (65 °C).



<b>V3642</b>		<b>Airflow, SCFM (m³/h)</b>								<b>Water Pressure Drop</b>			
<b>Entering Water Temp</b>	<b>Water Flow Rate</b>	500 (850)		750 (1270)		875 (1490)		1000 (1700)					
		°F	(°C)	GPM	(L/s)	<b>Total Capacity</b>							
		MBH	(kW)	MBH	(kW)	MBH	(kW)	MBH	(kW)	ft. w.c.	(kPa)		
100	(38)	2	(0.13)	11.1	3.26	14.0	4.10	15.1	4.42	16.0	4.68	0.72	(2.2)
		4	(0.25)	12.3	3.61	16.4	4.81	18.1	5.31	19.7	5.76	2.47	(7.4)
		6	(0.38)	12.7	3.72	17.3	5.07	19.3	5.65	21.1	6.18	5.08	(15.2)
		8	(0.50)	12.9	3.78	17.7	5.20	19.9	5.82	21.8	6.40	8.45	(25.3)
		10	(0.63)	13.0	3.82	18.0	5.28	20.2	5.93	22.3	6.53	12.55	(37.5)
120	(49)	2	(0.13)	18.7	5.47	23.5	6.89	25.3	7.43	26.9	7.88	0.72	(2.2)
		4	(0.25)	20.6	6.04	27.5	8.06	30.4	8.91	33.0	9.66	2.47	(7.4)
		6	(0.38)	21.2	6.22	28.9	8.48	32.3	9.46	35.3	10.35	5.08	(15.2)
		8	(0.50)	21.6	6.31	29.7	8.69	33.2	9.74	36.5	10.70	8.45	(25.3)
		10	(0.63)	21.7	6.37	30.1	8.82	33.8	9.91	37.3	10.92	12.55	(37.5)
140	(60)	2	(0.13)	26.2	7.69	33.2	9.71	35.7	10.47	37.9	11.10	0.72	(2.2)
		4	(0.25)	28.9	8.48	38.7	11.34	42.8	12.53	46.4	13.6	2.47	(7.4)
		6	(0.38)	29.8	8.73	40.7	11.91	45.4	13.29	49.6	14.55	5.08	(15.2)
		8	(0.50)	30.2	8.86	41.6	12.20	46.7	13.68	51.3	15.04	8.45	(25.3)
		10	(0.63)	30.5	8.93	42.2	12.38	47.5	13.91	52.3	15.34	12.55	(37.5)
160	(71)	2	(0.13)	33.9	9.93	42.8	12.55	46.2	13.53	49.0	14.36	0.72	(2.2)
		4	(0.25)	37.3	10.92	49.9	14.63	55.2	16.18	59.9	17.56	2.47	(7.4)
		6	(0.38)	38.4	11.25	52.4	15.36	58.5	17.14	64.0	18.77	5.08	(15.2)
		8	(0.50)	38.9	11.40	53.7	15.72	60.2	17.63	66.2	19.39	8.45	(25.3)
		10	(0.63)	39.2	11.50	54.4	15.94	61.2	17.92	67.5	19.77	12.55	(37.5)
Recommended No. of Outlets		15		23		27		30					

Capacities are based on 70°F (21°C) return air temperature ( $T_{in}$ )  
 Conversion Factors: MBH = 1000 Btu/hr, 1 kW = 3413 Btu/hr  
 Recommended number of outlets is based on 33 CFM (60 m³/h) per outlet for a quiet system.

**WARNING!**  
 To prevent injury or damage from high temperatures, do not install floor outlets when operating with discharge temperature above 160°F (71°C).

**Caution**  
 To prevent damage to the EC motor from overheating, do not operate in the shaded region where discharge temperature is more 150 °F (65 °C).

**Hot Water Coil Air Pressure Drop, in. w.c., (Pa)**

<b>Air Flow Rate</b>		<b>Hot Water Coil Model</b>					
		<b>HW-V2430</b>		<b>HW-V3036</b>		<b>HW-V3642</b>	
CFM	(m³/h)						
400	(680)	0.11	(26)	0.08	(20)	-	-
500	(850)	0.16	(39)	0.10	(25)	0.06	(15)
625	(1060)	0.23	(58)	0.15	(36)	0.09	(22)
750	(1270)	0.32	(80)	0.20	(50)	0.12	(31)
875	(1490)	-	-	0.27	(66)	0.16	(40)
1000	(1700)	-	-	0.34	(83)	0.21	(51)
1100	(1870)	-	-	-	-	0.24	(60)
1250	(2120)	-	-	-	-	-	-

**Note:** Evaluated at 70°F db (21°C)

**CHILLED WATER COIL PERFORMANCE (COOLING MODE)**

The performance tables below are based on 80°F db/67°F wb (27°C db/19°C wb) entering air and pure water. See capacity multiplier tables for correction factors for different temperatures and glycol concentrations.

V2430				Airflow												Water Pressure Drop	
Entering Water Temp		Water Flow Rate		300CFM (142 L/s)			400CFM (189 L/s)			500CFM (236L/s)			625CFM (295 L/s)				
				Total Capacity		SHR	Total Capacity		SHR	Total Capacity		SHR	Total Capacity		SHR		
°F	°C	GPM	L/s	MBH	kW	SHR	MBH	MBH	kW	MBH	kW	kW	MBH	kW	SHR	ft. w.g.	kPa
40	4.4	2	0.13	16.1	4.7	0.62	18.8	5.5	0.63	20.6	6.0	0.66	22	6.6	0.70	1.19	3.56
		4	0.25	18.3	5.4	0.60	22.8	6.7	0.60	26.6	7.8	0.62	30	8.9	0.63	4.06	12.14
		6	0.38	18.8	5.5	0.60	24.2	7.1	0.60	28.8	8.4	0.61	34	9.8	0.62	8.34	24.93
46	7.7	2	0.13	13.1	3.8	0.66	15.2	4.5	0.69	16.8	4.9	0.73	18	5.4	0.77	1.19	3.56
		4	0.25	15.0	4.4	0.63	18.6	5.5	0.64	21.6	6.3	0.66	24	7.2	0.68	4.06	12.14
		6	0.38	15.4	4.5	0.62	19.8	5.8	0.63	23.4	6.9	0.64	27	8.0	0.65	8.34	24.93
50	10.0	2	0.13	11.0	3.2	0.70	12.9	3.8	0.74	14.3	4.2	0.78	16	4.6	0.84	1.19	3.56
		4	0.25	12.6	3.7	0.66	15.7	4.6	0.68	18.1	5.3	0.70	21	6.0	0.72	4.06	12.14
		6	0.38	13.0	3.8	0.65	16.6	4.9	0.66	19.6	5.7	0.68	23	6.7	0.69	8.34	24.93
55	12.8	2	0.13	8.2	2.4	0.80	9.8	2.9	0.86	11.2	3.3	0.90	12	3.6	1.00	1.19	3.56
		4	0.25	9.4	2.8	0.74	11.7	3.4	0.77	13.5	4.0	0.81	16	4.5	0.84	4.06	12.14
		6	0.38	9.7	2.8	0.74	12.4	3.6	0.75	14.7	4.3	0.77	17	5.0	0.80	8.34	24.93
Recommended No. of Outlets				12			15			18			21				

V3036				Airflow												Water Pressure Drop	
Entering Water Temp		Water Flow Rate		500CFM (236 L/s)			600CFM (283L/s)			700CFM (330 L/s)			800CFM (378L/s)				
				Total Capacity		SHR	Total Capacity		SHR	Total Capacity		SHR	Total Capacity		SHR		
°F	°C	GPM	L/s	MBH	kW	SHR	MBH	kW	SHR	MBH	kW	SHR	MBH	kW	SHR	ft. w.g.	kPa
40	4.4	2	0.13	21.2	6.2	0.662	22.6	6.6	0.687	23.8	7.0	0.718	24.8	7.3	0.751	0.62	1.85
		4	0.25	27.2	8.0	0.614	30.4	8.9	0.623	37.0	10.8	0.640	39.5	11.6	0.639	2.11	6.31
		6	0.38	29.4	8.6	0.608	33.6	9.8	0.611	42.0	12.3	0.622	45.5	13.3	0.626	4.32	12.91
		8	0.50	30.4	8.9	0.600	35.2	10.3	0.605	44.5	13.0	0.614	48.5	14.2	0.620	7.19	21.49
45	7.2	2	0.13	17.9	5.2	0.697	19.3	5.7	0.741	23.0	6.7	0.780	24.0	7.0	0.808	0.62	1.85
		4	0.25	23.2	6.8	0.638	25.8	7.6	0.652	31.2	9.1	0.675	33.4	9.8	0.691	2.11	6.31
		6	0.38	25.0	7.3	0.625	28.4	8.3	0.633	35.2	10.3	0.645	38.5	11.3	0.657	4.32	12.91
		8	0.50	25.8	7.6	0.625	29.8	8.7	0.628	37.6	11.0	0.637	41.0	12.0	0.647	7.19	21.49
50	10.0	2	0.13	14.7	4.3	0.771	16.0	4.7	0.810	19.1	5.6	0.853	20.0	5.9	0.903	0.62	1.85
		4	0.25	18.7	5.5	0.686	20.8	6.1	0.717	25.4	7.4	0.742	27.0	7.9	0.764	2.11	6.31
		6	0.38	20.2	5.9	0.671	23.0	6.7	0.685	28.6	8.4	0.699	30.8	9.0	0.714	4.32	12.91
		8	0.50	20.8	6.1	0.665	24.0	7.0	0.668	30.2	8.9	0.683	33.2	9.7	0.695	7.19	21.49
55	12.8	2	0.13	11.5	3.4	0.892	12.7	3.7	0.930	15.1	4.4	1.000	16.2	4.7	1.000	0.62	1.85
		4	0.25	13.9	4.1	0.796	15.6	4.6	0.828	19.2	5.6	0.861	20.8	6.1	0.885	2.11	6.31
		6	0.38	15.0	4.4	0.766	17.2	5.0	0.784	21.2	6.2	0.810	23.2	6.8	0.824	4.32	12.91
		8	0.50	15.5	4.5	0.749	17.9	5.2	0.759	22.6	6.6	0.784	24.6	7.2	0.795	7.19	21.49
Recommended No. of Outlets				15			18			21			24				

V3642				Airflow												Water Pressure Drop	
Entering Water Temp		Water Flow Rate		600CFM (283L/s)			800CFM (378L/s)			1000CFM (472L/s)			1100CFM (519L/s)				
				Total Capacity		SHR	Total Capacity		SHR	Total Capacity		SHR	Total Capacity		SHR		
°F	°C	GPM	L/s	MBH	kW		MBH	kW		MBH	kW		MBH	kW		ft. w.g.	kPa
40	4.4	4	0.13	30.0	8.8	0.625	34.6	10.1	0.653	37.8	11.1	0.684	39.0	11.4	0.701	1.17	3.50
		6	0.25	33.4	9.8	0.611	40.0	11.7	0.626	44.5	13.0	0.644	46.5	13.6	0.655	2.39	7.14
		8	0.38	35.0	10.3	0.608	43.0	12.6	0.617	49.0	14.4	0.630	51.5	15.1	0.633	3.98	11.90
		10	0.50	36.0	10.6	0.613	45.0	13.2	0.612	52.0	15.2	0.619	55.0	16.1	0.624	5.91	17.66
45	7.2	4	0.13	25.4	7.4	0.656	29.2	8.6	0.692	32.0	9.4	0.732	33.2	9.7	0.757	1.17	3.50
		6	0.25	28.2	8.3	0.639	33.6	9.8	0.657	37.8	11.1	0.682	39.5	11.6	0.703	2.39	7.14
		8	0.38	29.8	8.7	0.624	36.2	10.6	0.644	41.5	12.2	0.660	43.5	12.7	0.675	3.98	11.90
		10	0.50	30.4	8.9	0.622	37.8	11.1	0.634	43.5	12.7	0.652	46.0	13.5	0.663	5.91	17.66
50	10.0	4	0.13	20.6	6.0	0.714	23.8	7.0	0.763	26.4	7.7	0.816	27.4	8.0	0.838	1.17	3.50
		6	0.25	22.8	6.7	0.690	27.2	8.0	0.717	30.6	9.0	0.758	32.0	9.4	0.776	2.39	7.14
		8	0.38	24.0	7.0	0.668	29.2	8.6	0.700	33.4	9.8	0.719	35.0	10.3	0.736	3.98	11.90
		10	0.50	24.8	7.3	0.664	30.6	9.0	0.686	35.2	10.3	0.708	37.2	10.9	0.717	5.91	17.66
55	12.8	4	0.13	15.5	4.5	0.823	18.3	5.4	0.895	20.0	5.9	1.000	21.2	6.2	1.000	1.17	3.50
		6	0.25	17.0	5.0	0.790	20.4	6.0	0.832	23.2	6.8	0.874	24.6	7.2	0.900	2.39	7.14
		8	0.38	17.9	5.2	0.759	21.8	6.4	0.799	25.0	7.3	0.836	26.6	7.8	0.853	3.98	11.90
		10	0.50	18.4	5.4	0.750	22.6	6.6	0.779	26.4	7.7	0.817	28.0	8.2	0.833	5.91	17.66
<b>Recommended No. of Outlets</b>				21			24			27			30				

**CHILLED WATER COIL PERFORMANCE (HEATING MODE)**

The performance tables below are based on 70°F db (21°C db) entering air. See capacity multiplier tables for correction factors for different temperatures and glycol concentrations.

V2430				Airflow								Water Pressure Drop	
Entering Water Temp		Water Flow Rate		300CFM (142 L/s)		400CFM (189 L/s)		500CFM (236L/s)		625CFM (295 L/s)			
				Total Capacity		Total Capacity		Total Capacity		Total Capacity			
°F	°C	GPM	L/s	MBH	kW	MBH	kW	MBH	kW	MBH	kW	ft. w.g.	kPa
95	35	2	0.13	7.2	2.1	9.3	2.7	11.1	3.3	12.9	3.8	1.19	3.56
		4	0.25	7.3	2.1	9.7	2.8	11.9	3.5	14.4	4.2	4.06	12.14
		6	0.38	7.4	2.2	9.7	2.8	12.1	3.5	14.8	4.3	8.34	24.93
110	43.3	2	0.13	11.6	3.4	15.0	4.4	17.8	5.2	20.8	6.1	0.86	2.57
		4	0.25	11.7	3.4	15.5	4.5	19.1	5.6	23.2	6.8	2.95	8.82
		6	0.38	11.8	3.5	15.6	4.6	19.3	5.7	23.6	6.9	6.06	18.11
120	48.9	2	0.13	14.5	4.2	18.7	5.5	22.4	6.6	26.0	7.6	0.86	2.57
		4	0.25	14.7	4.3	19.4	5.7	23.8	7.0	29.0	8.5	2.95	8.82
		6	0.38	14.7	4.3	19.5	5.7	24.2	7.1	29.6	8.7	6.06	18.11
140	60.0	2	0.13	20.4	6.0	26.2	7.7	31.4	9.2	36.6	10.7	0.86	2.57
		4	0.25	20.6	6.0	27.2	8.0	33.4	9.8	40.5	11.9	2.95	8.82
		6	0.38	20.6	6.0	27.4	8.0	33.8	9.9	41.5	12.2	6.06	18.11
160	71.1	2	0.13	26.2	7.7	33.8	9.9	40.5	11.9	47.0	13.8	0.86	2.57
		4	0.25	26.4	7.7	35.0	10.3	43.0	12.6	52.5	15.4	2.95	8.82
		6	0.38	26.6	7.8	35.2	10.3	43.5	12.7	53.5	15.7	6.06	18.11
<b>Recommended No. of Outlets</b>				12		15		18		21			

**WARNING!**  
 To prevent injury or damage from high temperatures, do not install floor outlets when operating with discharge temperature above 160°F (71°C).

**Caution**  
 To prevent damage to the EC motor from overheating, do not operate in the shaded region where discharge temperature is more 150 °F (65 °C).

V3036				Airflow								Water Pressure Drop	
Entering Water Temp		Water Flow Rate		500CFM (236 L/s)		600CFM (283L/s)		700CFM (330 L/s)		800CFM (378L/s)			
				Total Capacity		Total Capacity		Total Capacity		Total Capacity			
°F	°C	GPM	L/s	MBH	kW	MBH	kW	MBH	kW	MBH	kW	ft. w.g.	kPa
95	35	2	0.13	11.3	3.3	12.9	3.8	14.1	4.1	15.1	4.4	0.62	1.85
		4	0.25	12.0	3.5	14.2	4.2	16.1	4.7	17.9	5.2	2.11	6.31
		6	0.38	12.2	3.6	14.4	4.2	16.6	4.9	18.7	5.5	4.32	12.91
		8	0.50	12.2	3.6	14.5	4.2	16.8	4.9	19.0	5.6	7.19	21.49
110	43.3	2	0.13	18.2	5.3	20.6	6.0	22.8	6.7	24.4	7.2	0.45	1.35
		4	0.25	19.3	5.7	22.8	6.7	26.0	7.6	28.8	8.4	1.53	4.57
		6	0.38	19.5	5.7	23.2	6.8	26.6	7.8	30.0	8.8	3.14	9.39
		8	0.50	19.5	5.7	23.2	6.8	26.8	7.9	30.4	8.9	5.22	15.60
120	48.9	2	0.13	22.8	6.7	26.0	7.6	28.6	8.4	30.6	9.0	0.45	1.35
		4	0.25	24.2	7.1	28.4	8.3	32.4	9.5	36.2	10.6	1.53	4.57
		6	0.38	24.4	7.2	29.0	8.5	33.4	9.8	37.4	11.0	3.14	9.39
		8	0.50	24.4	7.2	29.0	8.5	33.6	9.8	38.0	11.1	5.22	15.60
140	60.0	2	0.13	32.0	9.4	36.4	10.7	40.0	11.7	43.0	12.6	0.45	1.35
		4	0.25	33.8	9.9	40.0	11.7	45.5	13.3	50.5	14.8	1.53	4.57
		6	0.38	34.0	10.0	40.5	11.9	46.5	13.6	52.5	15.4	3.14	9.39
		8	0.50	34.2	10.0	41.0	12.0	47.0	13.8	53.5	15.7	5.22	15.60
160	71.1	2	0.13	41.5	12.2	47.0	13.8	52.0	15.2	55.5	16.3	0.45	1.35
		4	0.25	43.5	12.7	51.5	15.1	58.5	17.1	65.5	19.2	1.53	4.57
		6	0.38	44.0	12.9	52.0	15.2	60.0	17.6	67.5	19.8	3.14	9.39
		8	0.50	44.0	12.9	52.5	15.4	60.5	17.7	68.5	20.1	5.22	15.60
<b>Recommended No. of Outlets</b>				15		18		21		24			

**WARNING!**  
 To prevent injury or damage from high temperatures, do not install floor outlets when operating with discharge temperature above 160°F (71°C).

**Caution**  
 To prevent damage to the EC motor from overheating, do not operate in the shaded region where discharge temperature is more 150 °F (65 °C).

V3642				Airflow								Water Pressure Drop	
Entering Water Temp		Water Flow Rate		600CFM (283L/s)		800CFM (378L/s)		1000CFM (472L/s)		1100CFM (519L/s)			
				Total Capacity		Total Capacity		Total Capacity		Total Capacity			
°F	°C	GPM	L/s	MBH	kW	MBH	kW	MBH	kW	MBH	kW	ft. w.g.	kPa
95	35	4	0.13	14.1	4.1	17.9	5.2	21.0	6.2	22.2	6.5	1.17	3.50
		6	0.25	14.4	4.2	18.6	5.5	22.4	6.6	24.0	7.0	2.39	7.14
		8	0.38	14.5	4.2	19.0	5.6	23.0	6.7	24.8	7.3	3.98	11.90
		10	0.50	14.6	4.3	19.1	5.6	23.4	6.9	25.2	7.4	5.91	17.66
110	43.3	4	0.13	22.6	6.6	28.8	8.4	33.8	9.9	35.8	10.5	0.85	2.54
		6	0.25	23.2	6.8	30.0	8.8	36.0	10.6	38.5	11.3	1.74	5.20
		8	0.38	23.2	6.8	30.4	8.9	36.8	10.8	40.0	11.7	2.89	8.64
		10	0.50	23.4	6.9	30.6	9.0	37.4	11.0	40.5	11.9	4.3	12.85
120	48.9	4	0.13	28.4	8.3	36.0	10.6	42.5	12.5	45.0	13.2	0.85	2.54
		6	0.25	29.0	8.5	37.4	11.0	45.0	13.2	48.5	14.2	1.74	5.20
		8	0.38	29.2	8.6	38.0	11.1	46.0	13.5	50.0	14.7	2.89	8.64
		10	0.50	29.2	8.6	38.5	11.3	47.0	13.8	51.0	14.9	4.3	12.85
140	60.0	4	0.13	40.0	11.7	50.5	14.8	59.5	17.4	63.5	18.6	0.85	2.54
		6	0.25	40.5	11.9	52.5	15.4	63.5	18.6	68.0	19.9	1.74	5.20
		8	0.38	41.0	12.0	53.5	15.7	65.0	19.0	70.0	20.5	2.89	8.64
		10	0.50	41.0	12.0	53.5	15.7	65.5	19.2	71.0	20.8	4.3	12.85
160	71.1	4	0.13	51.5	15.1	65.5	19.2	77.0	22.6	82.0	24.0	0.85	2.54
		6	0.25	52.0	15.2	67.5	19.8	81.5	23.9	88.0	25.8	1.74	5.20
		8	0.38	52.5	15.4	68.5	20.1	83.5	24.5	90.5	26.5	2.89	8.64
		10	0.50	52.5	15.4	69.0	20.2	84.5	24.8	92.0	27.0	4.3	12.85
<b>Recommended No. of Outlets</b>				21		24		27		30			

**WARNING!**  
 To prevent injury or damage from high temperatures, do not install floor outlets when operating with discharge temperature above 160°F (71°C).

**Caution**  
 To prevent damage to the EC motor from overheating, do not operate in the shaded region where discharge temperature is more 150 °F (65 °C).

**BLOWER PERFORMANCE**

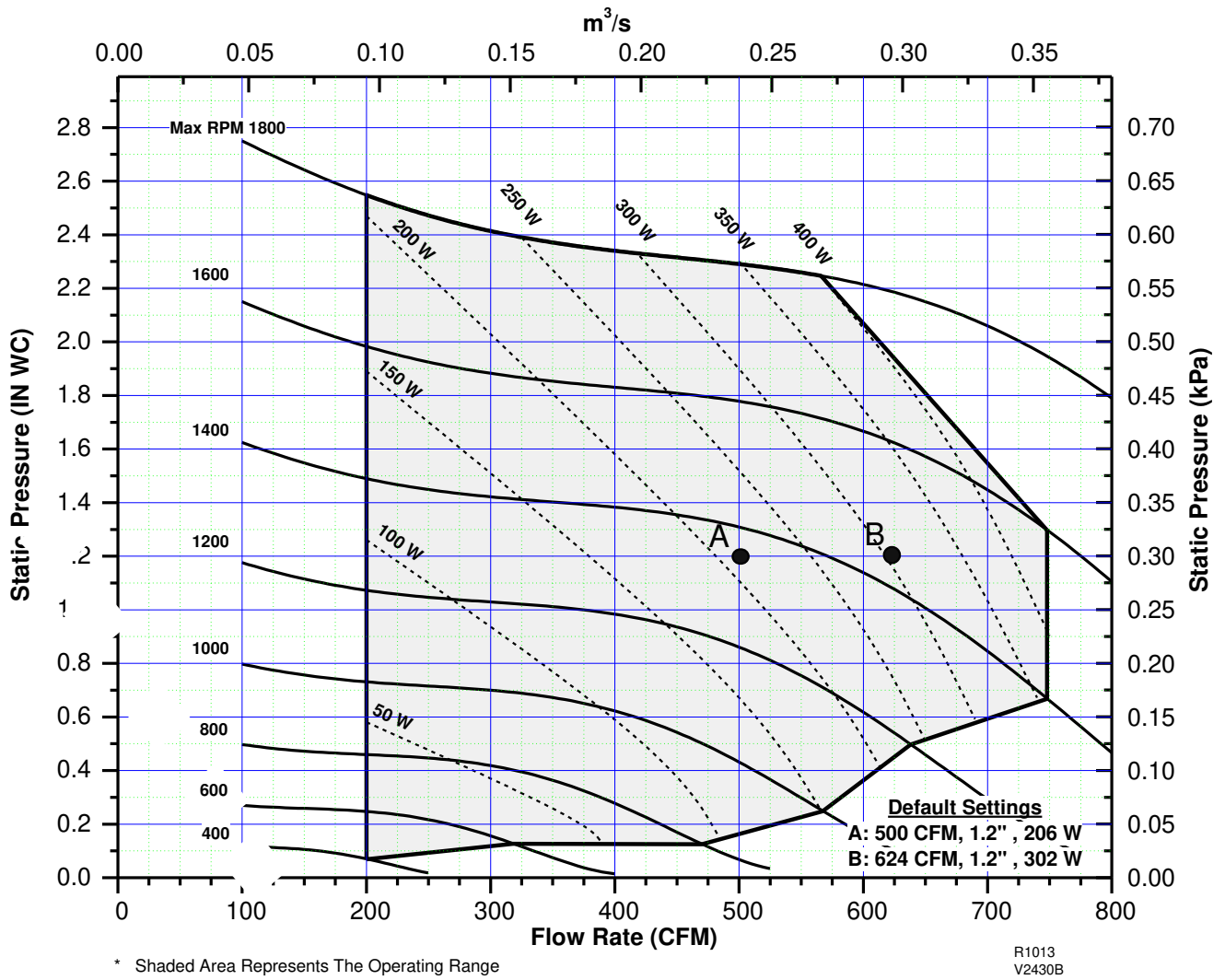

**Figure 1. V2430BL-1EC Blower Performance**

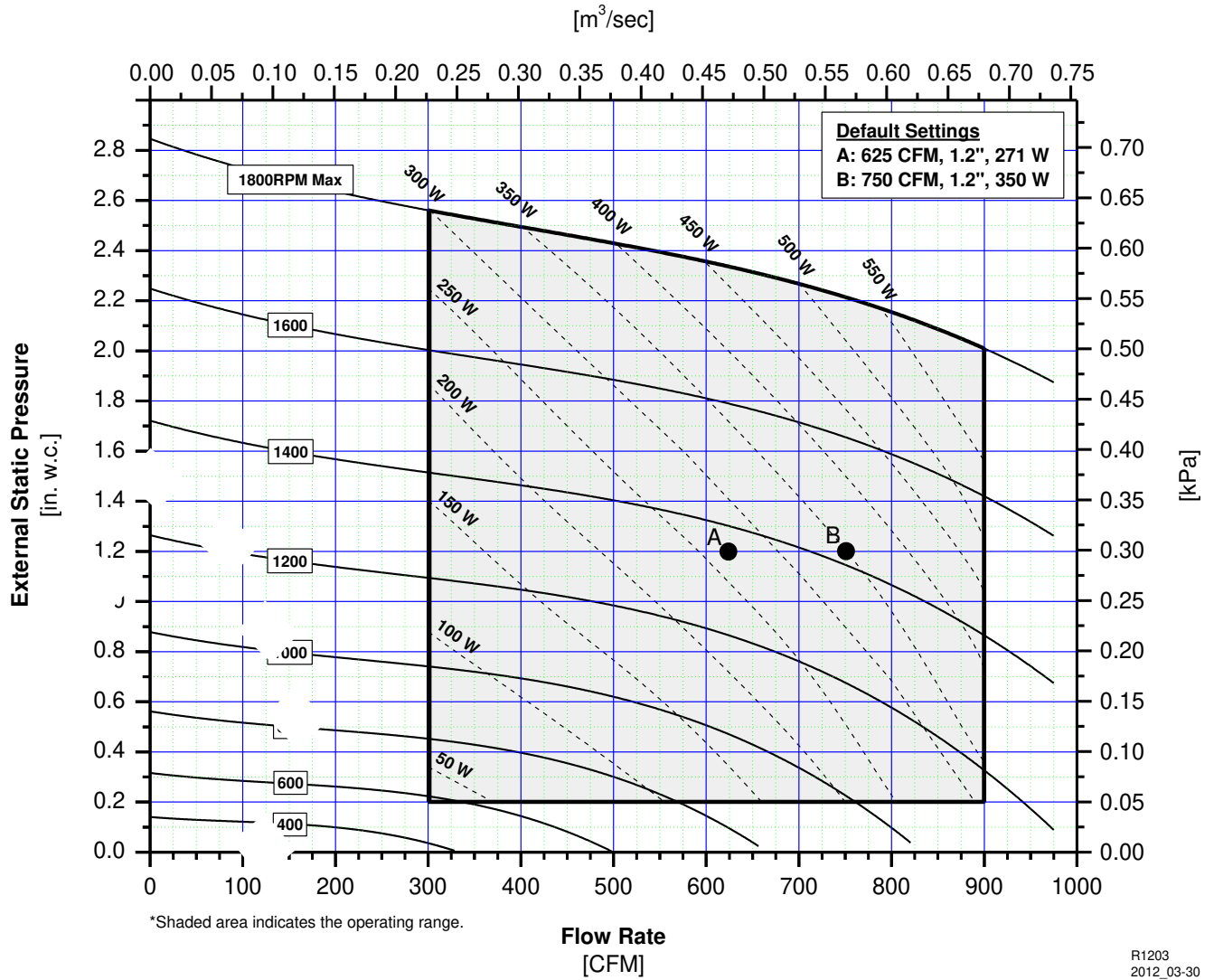

Figure 2. V3036BL-1EC Blower Performance

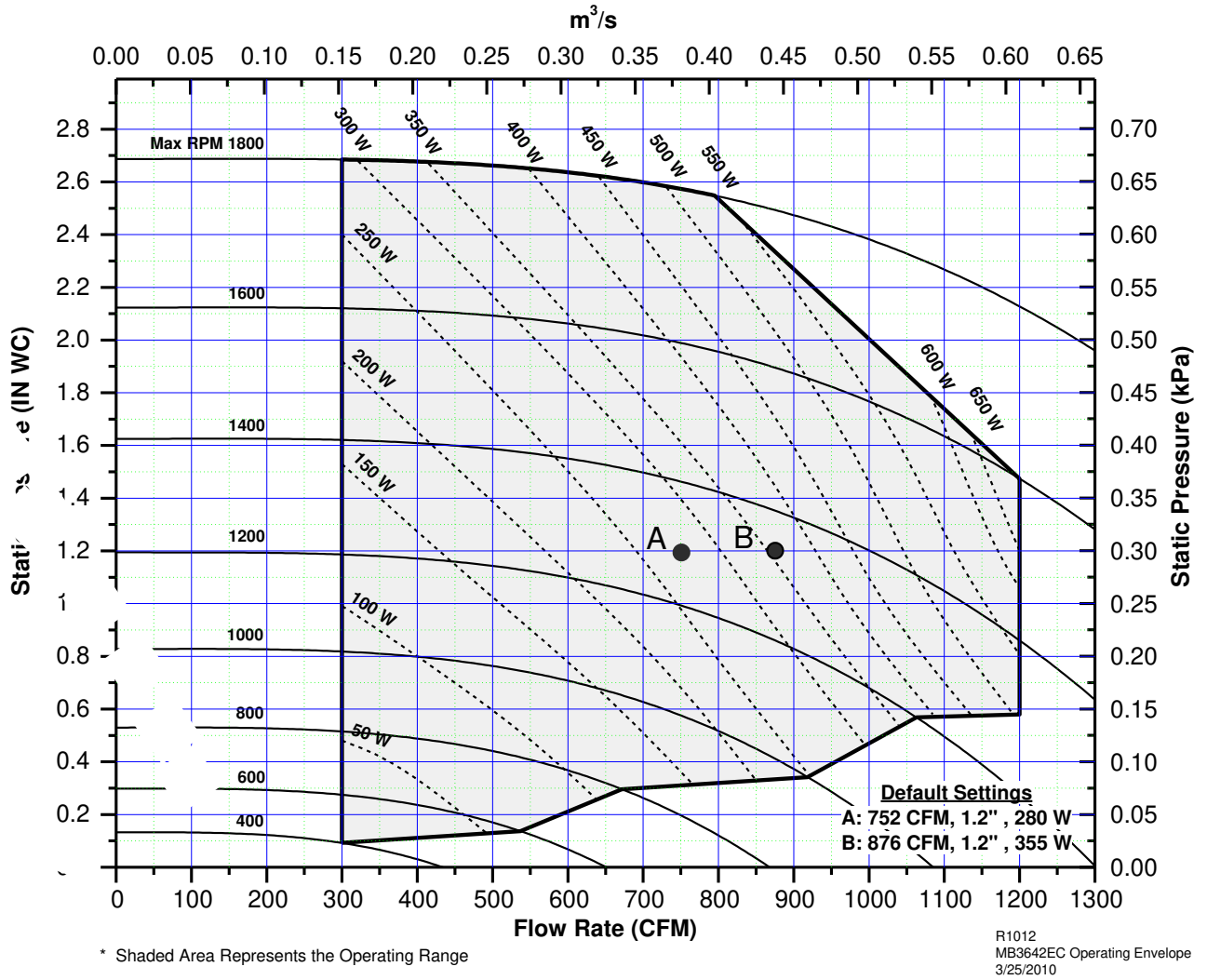

Figure 3. V3642BL-1EC Blower Performance



## ACOUSTICAL DATA

Sound is always present and is important to comfort. Understanding how sound is defined is essential to understanding how to design a proper Unico System. Sound is defined as a physical disturbance in pressure that is detectable by the human ear. Sound is usually presented as Sound Pressure Level (SPL) in decibels (dB), but can also be presented as Sound Power Level (SWL). Sound pressure is what you hear so it is the only value that is important to the occupant. However, determining the value is difficult because it is dependent on the surroundings and distance from the sound source. For instance, a carpeted room is much quieter than a room with wood floors.

For the Unico System, it is also important to consider sound transmission losses through ceilings and walls. The blower is never placed in the occupied room so the sound is always less than the published value. This reduction in sound level depends on the construction of the ceiling or wall. For instance, a ceiling structure made of gypsum board with insulation above it will have a much greater sound transmission loss (TL) than a dropped ceiling without insulation.

The data shown in this catalog was measured in a large room with hard surfaces for the walls and floor. It is considered to be the worst case (i.e. loudest). The sound level in the occupied space will always be considerably less than this, depending on where the unit is located. To determine the actual sound level, subtract the TL for the barrier from the sound data of the unit. The table below shows typical TL values for common construction configurations. Subtract these values from the Unico air handler data.

Transmission Loss for Common Construction, dB

Frequency, Hz	125	250	500	1k	2k	4k	R
Sheet Metal, 24 GA	13	17	20	27	34	39	<b>18</b>
Ceiling Tile, mineral fiber	13	21	27	31	35	40	<b>20</b>
Gypsum Frame wall	12	23	31	38	42	37	<b>20</b>
Gypsum Frame wall, insul.	15	30	32	43	46	38	<b>23</b>
Wood Floor, uninsulated	22	28	37	43	46	43	<b>25</b>
Wood Floor, insulated	29	40	51	57	60	58	<b>26</b>
Concrete Block, 190-mm	38	41	43	50	55	61	<b>26</b>
Concrete, 100-mm (4 in.)	41	41	45	52	56	64	<b>26</b>

Ref: *Handbook of Acoustical Measurements and Noise Control*, 1998

R = Overall Loss for typical Blower Module (based on MB4260H-50HZ)

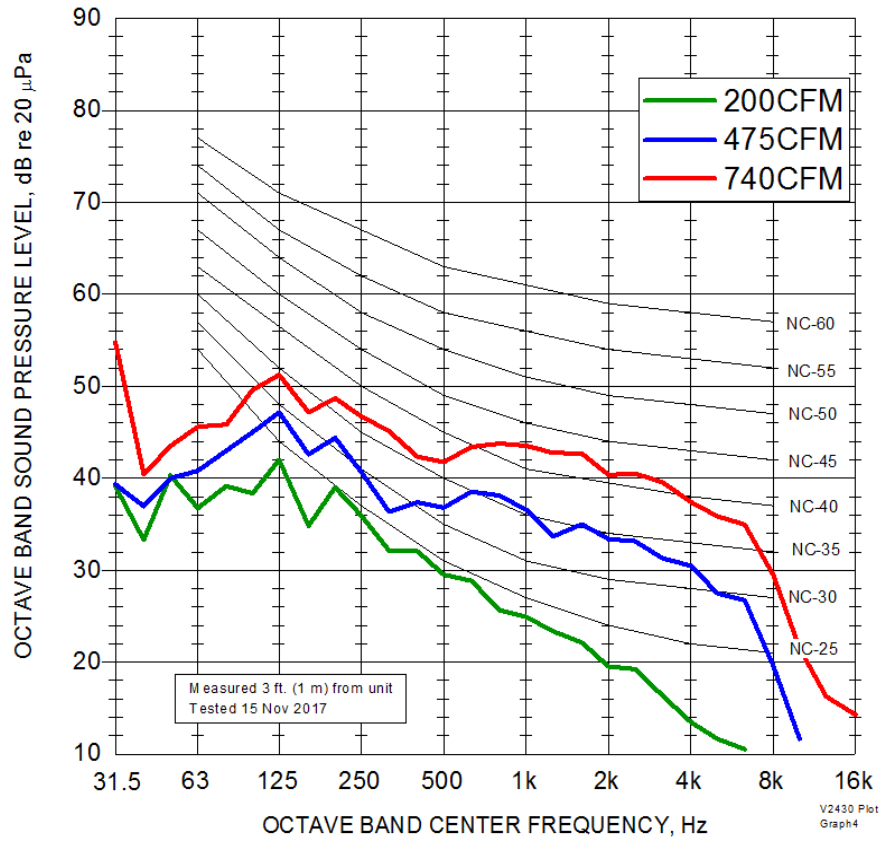

**Figure 4. V2430BL-1EC Raw Sound Data**

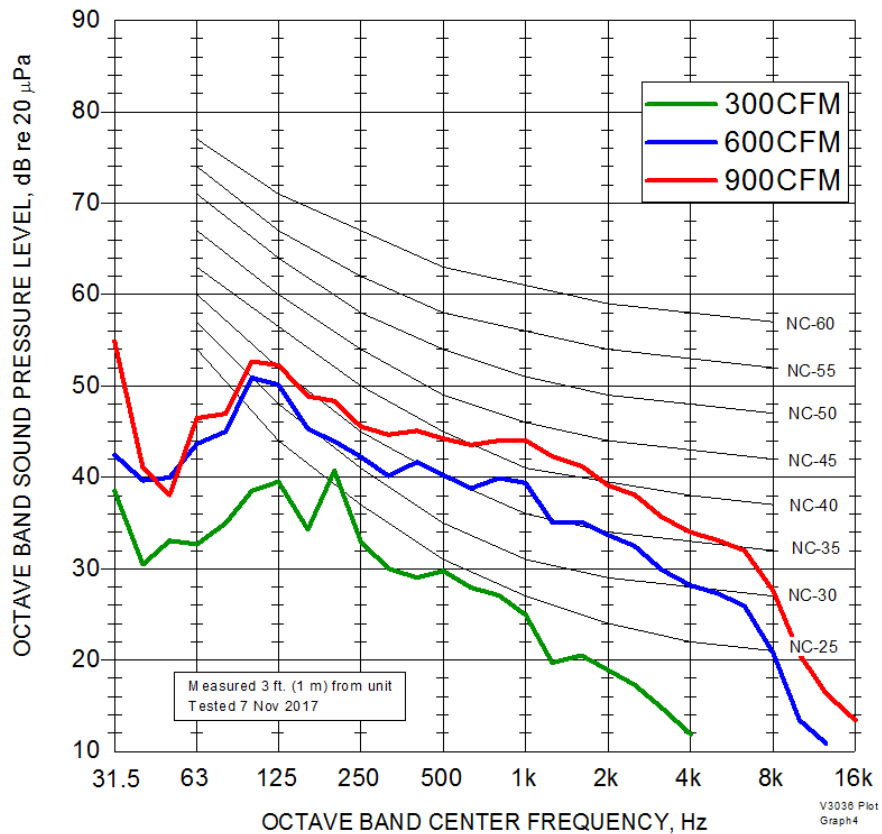

**Figure 5. V3036BL-1EC Raw Sound Data**

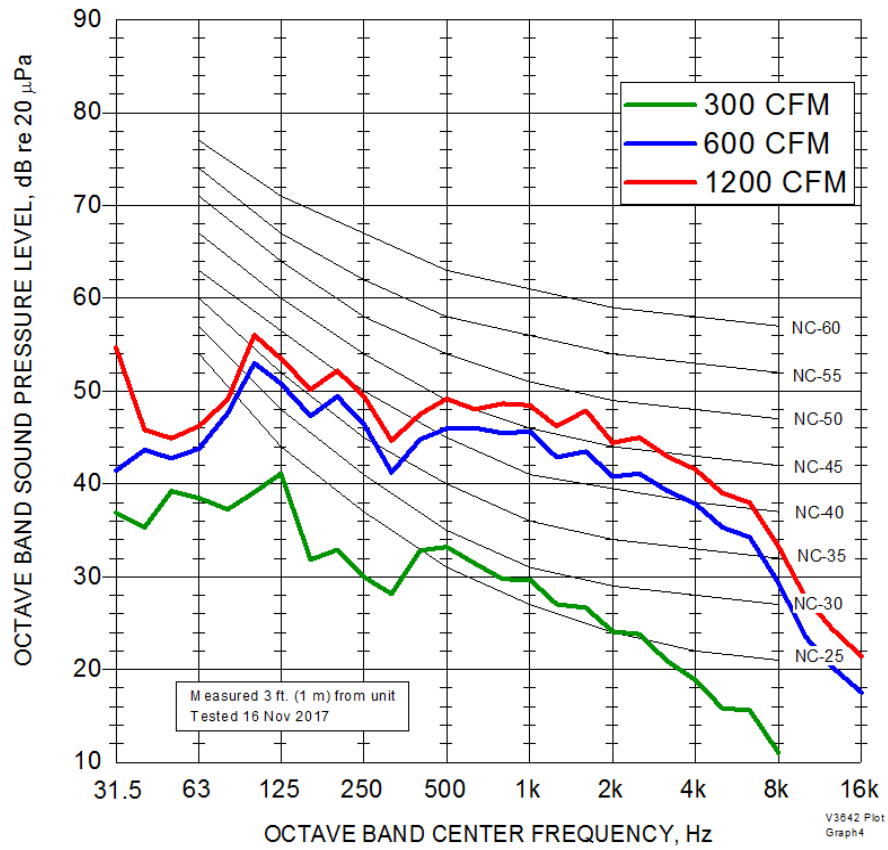

Figure 6. V3642BL-1EC Raw Sound Data